

# HV SERIES

Air Purifiers | For Breathable Areas



hepavent®

hepavent®

Engineered air purification systems

www.hepavent.com

+90 850 303 54 56

info@hepavent.com

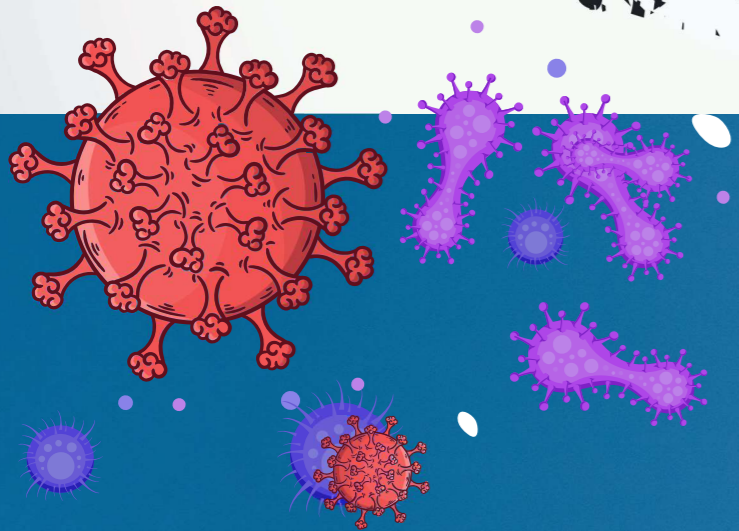
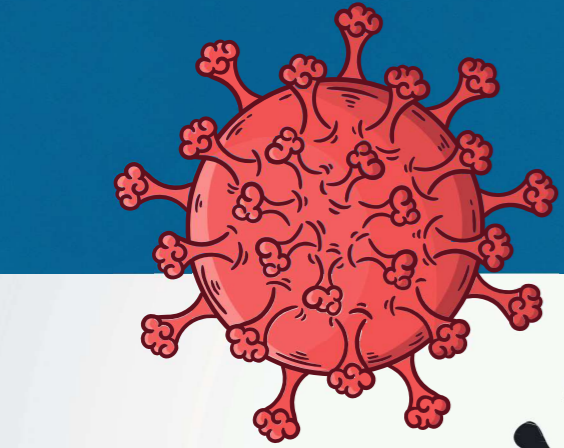
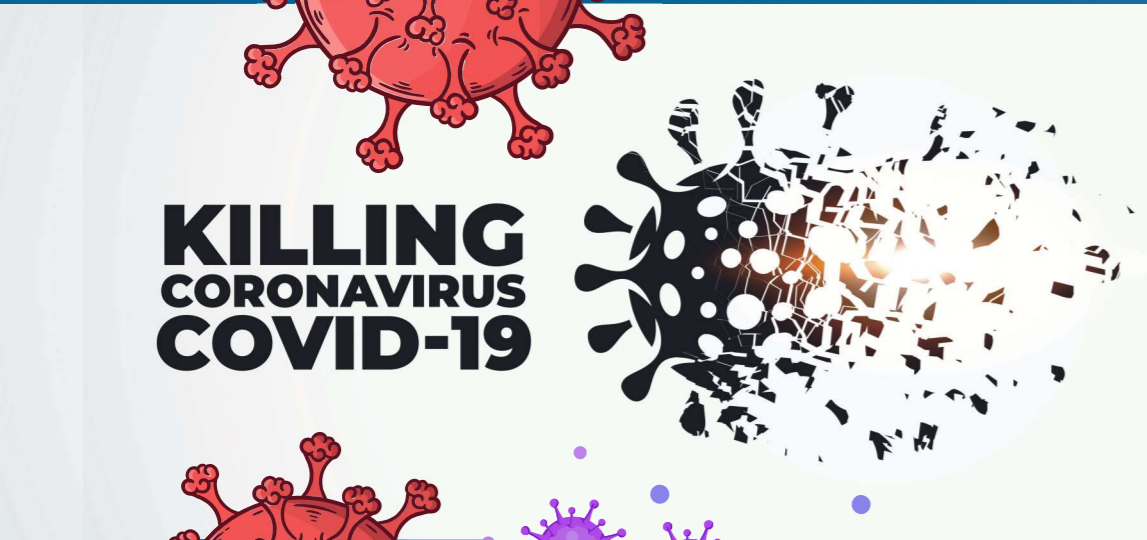

**CLEAN AIR THROUGH  
HEPAVENT'S  
HIGH QUALITY  
AIR DISINFECTION**

For healthcare facilities  
and all living spaces  
required  
hygienic environment

Areas which are needed to have  
maximum clean airflow ;

- Hospitals
- Laboratories
- Dental areas
- Areas causing respiration sensitivities
  - Dusty places
  - Pathology work spaces
  - Hematology units
  - Smoking areas
- Post-transplantation areas
  - General air cleaning
- Hair transplantation bases
  - Schools
  - Shopping Malls
  - Hotels
  - Offices
  - Banks
  - Sport Centres
  - Hair dressers  
and etc.



**We eliminate the particles, microorganisms, viruses and bad odors from the air and provide healthy air to the surrounding.**

**How do we clean?**

\*Micron size particles including mold, virus, bacteria, pollen, dust, printer toner fumes are efficiently captured by the strong electrical field of electrostatic filter.

\*Specific carbon filter absorbs chemical fumes and bad odors in health related areas and bad odors (organic volatile molecules) in public spaces, thus provides a fresh and clean air.

\*By the exposure to 253,7 nm wavelength UVC lamp, nucleic acids of viruses and small microorganisms which are able to cause infections and contaminations are disrupted, thus spreading of infectious diseases is stopped and risk of contamination is prevented.

With the increase of contaminants causing contamination, the increase in the number of patients with immune system deficiency has become a serious problem in the hospital environment. The cost of infections in the air is very high in terms of both human life and financial costs.

Consequently, there is a general need to ensure that the air in the hospital setting (all over the facility) has the highest possible quality.

Medically controlled air is the only reliable solution and it is the most important and precise solution: air pollution must be eliminated.

There is no point in cleaning the air only a little.

Air is a major 'carrier' of infections, and infections in the air are neither limited by certain sources nor by limits. There are a huge number of potential sources of infection, from outdoor air to flawed ventilation systems, from building materials to personnel, visitors or people who can become ill.

**Important fact**

An important fact is that the vast majority of airborne infections develop within healthcare facilities and crowded social areas.

That's why we produced units that solve the problem at its source and prevent it from spreading.

**H14 HEPA  
EN 1822 FILTER**

**EN 16890 ESP  
FILTER** **ILH BERLIN**  
INSTITUT FÜR LUFTHYGIENE

**Radial FAN EC  
LOW ENERGY**



**Germicidal  
ultraviolet chamber**



**Extruded  
Activated  
Carbon**

# HV range

INDOOR AIR EXCELLENCE



The device reduces intensity and time aerosol particles and suspended matter stay in the air, effectively operating directly at the site of installation. Wherever this flexible high-performance air purifier will be positioned: Depending on the required air change rate, the device will produce a purified and filtered "clean zone area" of up to 650 cubic meters of air. In this treatment zone, the surrounding air will be prevented from germs, fine particulates or other airborne micro particles since the device is able to perform large-volume air intakes of contaminated room air.

All thanks to effective filtration and a flexibly adjustable air circulation for the respective zone that will be free from aerosol particles. In Combinations with the integrated UVC systems, HEPA or ESP filter guarantees to separate airborne germs, viruses and dust, bacteria, spores or micro fibres from paper or textiles.



**ELECTROSTATIC FILTRATION\*\* (ESP)**



**H14 HEPA FILTER**



**UVC GERMICIDAL HIGH DOSAGE**



**F7 COMPACT FILTER**



**CARBON ACTIVATED GRANULE**

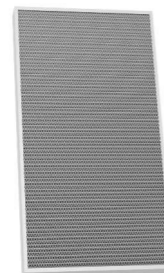

**G2 FILTER**

## How does the coronavirus spread?

The COVID 19 pandemic has become a major threat to humankind infecting millions world-wide. So far, we considered two main routes of infection:

- 1) indirect contact-by inhaling droplets emitted through sneezes and cough
- 2) direct contact with object that has virus on it

In a recent study by United State National Academy of Sciences, Engineering & Medicine, revealed a new way through which the virus spreads quickly along with the evidence of asymptomatic spread of the disease.

The study reported that even breathing or talking could possibly release tiny particles (Bioaerosols) carrying the SARS-CoV-2 virus which causes COVID 19. The team explained that the virus can stay suspended in the air in the ultrafine mist that is produced when infected people exhale. They recommended wearing masks while going out in public places.

Another experimental study was also conducted at Toho University in Japan by the Japanese Association for Infectious Disease to find out the third mechanism of transmission of COVID -19 using laser beams and high sensitivity camera to trap droplets particle in the air during sneezing, loud conversation and breathing.

They reported about micro-droplets infection as the third route of transmission in COVID 19. The micrometer particles which carries many viruses are very small particles (10 µm) releases during sneezing, loud conversation and heavy breathing drift in the air which might causes infection. However, the larger droplets (about 1mm) in diameter quickly falls after sneezing.

-Sneezing releases micro droplets drifting in the air which might carry virus.

-Micro droplets during loud conversation and heavy breathing.

-A person cough once and spread about 1000 macro droplets which falls down after 30 seconds and micro droplets drift inside the closed room even after 20 mins.

-To conclude, the limitations of their experiment is that it is not yet known what volume of micro droplets leads to infection.

-The studies recommend filtering air to prevent from micro droplets infection, however, they do not highlight what type of mask one's should wear since the micro droplets are very tiny. Therefore, there is a need to use high quality air purification units and fresh air supply to prevent aerosols covid-19 transmission.

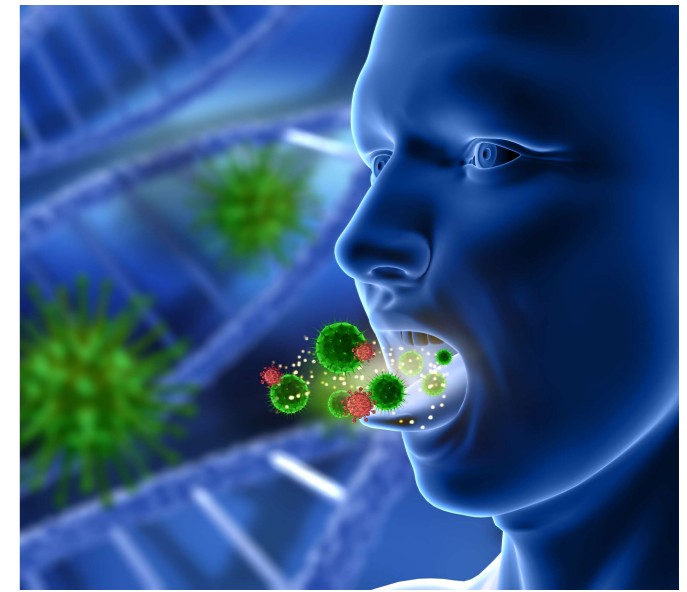

Portable Air Purifier :

# HV ECO



- PLC Control
- Compact Design
- Well Filtering
- Radial EC Fan
- Plug and Play
- Low Energy Cost
- Low Sound Level

Green Technology  
EC Centrifugal Fan



medical grade wheels

## FILTERS



Its powerful motor only needs a few minutes to provide a room up to 70 m<sup>2</sup> with fresh, clean air.

By choosing HV ECO range air purifier, you get a filter package that will deliver consistent performance and a high level of efficiency throughout its lifetime. It will also be more sustainable and greener than most other solutions.

### HV ECO air cleaners with H14 HEPA high-performance filters enable effective virus filtering

For particle filtration, we use HEPA filters (HEPA 14) according to standard EN 1822, or ePM1 (60 or 80%) according to standard ISO 16890.

#### Effective filtering with a transmittance ≤ 0.005 %

A filtration efficiency of 99.995 % means that 99.995 suspended particles of 100,000 are held back with a H14 filter and only 5 particles pass the filter. The filtration efficiency of H14 filters is therefore ten times higher than that of H13 HEPA filters.

- Meets WHO / CDC / ECDC air filtration guidelines
- Healthier Indoor Environment
- Reduce Environment Impact
- Less Asthma and Allergy Suffering
- Reduce PM1 and PM2.5
- Low Power Consumption
- Less Odour
- Completely Silent so as NOT to Disturb you

#### Additional Benefits ;

- The integrated PLC control will make its use and programming
- Filters status and alarms on screen
- Plug & Play, Easy to install
- Easy to service and cleaning
- UVC filter life counter/alarm
- Low pressure drop – the air flow through the filters is maintained for a long time
- EC type high efficiency fan with variable speed control
- Double panel insulated

#### Application ;

- \* Healthcare Facilities
- \* Dental Clinics
- \* Laboratories
- \* Biotech & Pharmaceutical Facilities
- \* Veterinary Clinics
- \* Hair Transplant Clinics



#### Specifications ;

Control	PLC-LCD Touch screen 7"
Max. Air Flow Rate	650 m <sup>3</sup> /h
Max. Effective Area*	up to 70 m <sup>2</sup>
Power Supply (230V)	526 Watt
Max. Sound Level @ 3m	58 dBA
Filter 1	G2 Cassette
Filter 2	F7 Compact
Filter 3	H14 Hepa
Weight	48 kg

#### Dimensions (mm) ;

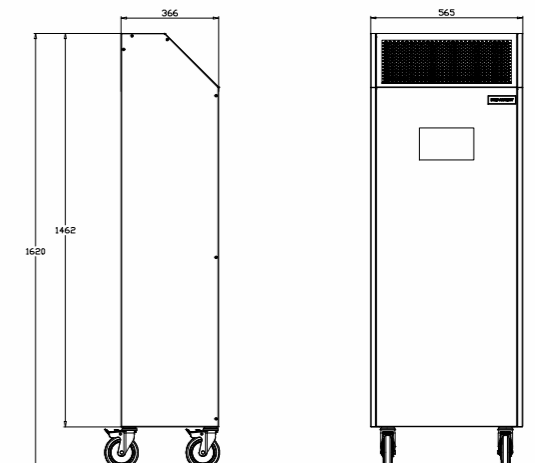

\*Clean zone area (hmax : 3m) with 3 air exchanges/hour

Portable Air Purifier :

# HV MED



- ★ PLC Control
- ★ Compact Design
- ★ Well Filtering
- ★ Radial EC Fan
- ★ Plug and Play
- ★ Low Energy Cost
- ★ Low Sound Level

 Green Technology  
EC Centrifugal Fan



medical grade wheels

## FILTERS



H14 HEPA

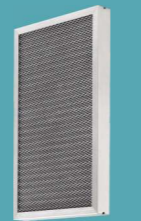

ACTIVATED CARBON



UVC GERMICIDAL



F7 COMPACT

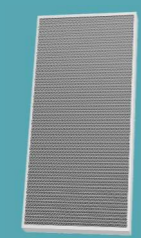

G2

**Our Portable Medical-Grade Air Purifier Delivers Hospital-Level Protection and HEPA-True Filtration to Safeguard**

**HV MED range air purifiers are designed to purify air at a molecular level and some are specifically germicidal and used for deactivating viruses and bacteria.**

- For particle filtration, we use HEPA filters (HEPA 14) according to standard EN 1822, or ePM1 (60 or 80%) according to standard ISO 16890.
- The special high dosage UV-C lamp in the HV MED kills bacteria, viruses, moulds and other primitive organisms in a safe and efficient manner.

- Activated charcoal is an absorbent filter that will retain certain vapors passing through it to filter odors or chemical gases which kept viruses hanging in the air for a long time.

- Meets WHO / CDC / ECDC air filtration guidelines
- Healthier Indoor Environment
- Prevents microbial contamination
- Reduce Environment Impact
- Less Asthma and Allergy Suffering
- Reduce PM1 and PM2.5
- Low Power Consumption
- Less Odour
- Completely Silent

**Additional Benefits ;**

- The integrated PLC control will make its use and programming
- Filters status and alarms on screen
- Plug & Play, Easy to install
- Easy to service
- UVC filter life counter/alarm
- Low pressure drop – the air flow through the filters is maintained for a long time
- EC type high efficiency fan with variable speed control

**Application ;**

While HV MED air cleaners are used in areas such as HV ECO models, they are additionally used in Microbiology labs, Sterilization zones, Mobile clinics, Surgery preparation and recovery rooms, GMP production areas.



**Specifications ;**

Control	PLC-LCD Touch screen 7"
Max. Air Flow Rate	650 m <sup>3</sup> /h
Max. Effective Area*	up to 70 m <sup>2</sup>
Power Supply (230V)	616 Watt
Max. Sound Level @ 3m	56 dBA
Filter 1	G2 Cassette
Filter 2	F7 Compact
Filter 3	UVC Germicidal
Filter 4	Activated Carbon
Filter 5	H14 Hepa
Weight	51 kg

\*Clean zone area (hmax : 3m) with 3 air exchanges/hour

**Dimensions (mm) ;**

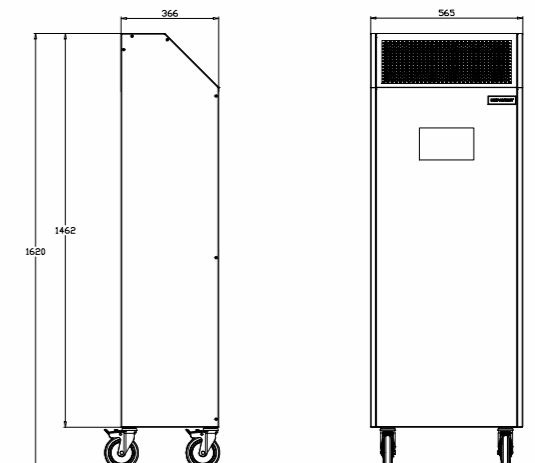

Portable Air Purifier :

# HV PRO



- ★ ★ ★ ★ ★ PLC Control
- ★ ★ ★ ★ ★ Compact Design
- ★ ★ ★ ★ ★ Well Filtering
- ★ ★ ★ ★ ★ Radial EC Fan
- ★ ★ ★ ★ ★ Plug and Play
- ★ ★ ★ ★ ★ Low Energy Cost
- ★ ★ ★ ★ ★ Low Sound Level

 **Green Technology EC Centrifugal Fan**



medical grade wheels

## FILTERS



H14 HEPA

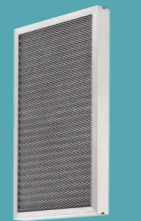

ACTIVATED CARBON



UVC GERMICIDAL



Electrostatic Precipitator



G2

**Effectiveness at inactivating 99% of viruses and bacteria on first pass. Trusted air purification with first-pass efficiency.**

- Prevents microbial contamination
- Reduce cross contamination

- Suggested for food product contact to Improve product shelf life
- Reduce PM1 and PM2.5 , Less Asthma and Allergy Suffering
- Healthier Indoor Environment, Less Odour
- Completely Silent , Low Power Consumption
- Meets WHO / CDC / ECDC air filtration guidelines

• Thanks to its high collection efficiency of submicronic particles and to its strong electric field, the ESP filter has an elevated antibacterial power and is active on pollen, fine dust, toner, mold, smog, viruses, bacteria and tobacco smoke.

• The Hygiene Institute of Berlin, which has been operating since a long time on the research, ventilation, environmental technology, medicine and hygiene fields, has certified that our electrostatic filters are able to remove from the air the airborne bacteria, yeasts and molds with a level of efficiency that goes from 98% to 99%.

• The special high dosage UV-C lamp in the HV PRO kills bacteria, viruses, moulds and other primitive organisms in a safe and efficient manner.

• Activated charcoal is an absorbent filter that will retain certain vapors passing through it to filter odors or chemical gases which kept viruses hanging in the air for a long time.

**Additional Benefits ;**

- The integrated PLC control will make its use and programming
- Datalog
- Filters status and alarms on screen
- Plug & Play, Easy to install , Easy to service and cleaning
- UVC filter life counter/alarm,
- H14 Hepa filter
- EC type high efficiency fan with variable speed control
- Low Life Cycle Cost (LCC) thanks to low energy consumption, long life of the air filters, minimal downtime and low service costs.

**Application ;**

While HV PRO air cleaners are used in areas such as HV MED models, they are additionally used in places where the risk of virus and disease transmission is very high like hospitals. It is preferred in busy areas where long-term use and long filter life is required.

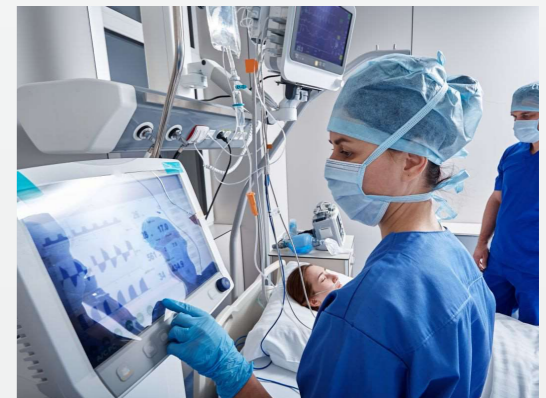

**Specifications ;**

Control	PLC-LCD Touch screen 7"
Max. Air Flow Rate	650 m <sup>3</sup> /h
Max. Effective Area*	up to 70 m <sup>2</sup>
Power Supply (230V)	634 Watt
Max. Sound Level @ 3m	57 dBA
Filter 1	G2 Cassette
Filter 2	Electrostatic Precipitator
Filter 3	UVC Germicidal
Filter 4	Activated Carbon
Filter 5	H14 Hepa
Weight	55 kg

\*Clean zone area (hmax : 3m) with 3 air exchanges/hour

**Dimensions (mm) ;**

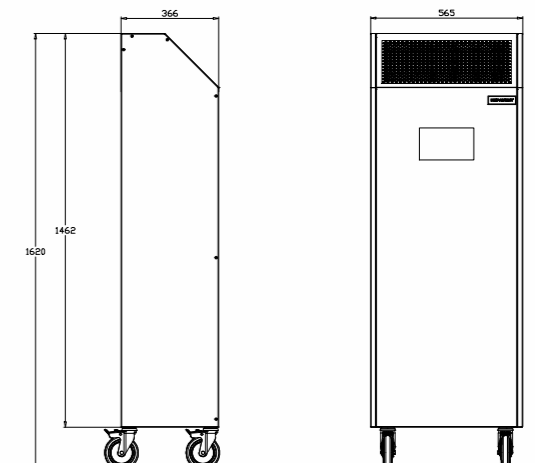

# HV PRO datalog

## Record Indoor Air quality Data to avoid risks Why we suggest Smart Control ?

JUST TOUCH IT TO CONTROL IT : The intelligence of the Smart Control is easily and intuitively controlled via the touch screen's user interface. Smart models have precise PM2,5 sensor measures the number of particles in the air. So you can datalog air quality with 7" touch panel control unit. When in automatic mode, the ventilator adapts to the current air quality indicating with;

Air Quality Index (AQI) Values	Levels of Health Concern	Colours
0 to 50	Good	Green
51 to 100	Moderate	Yellow
101 to 150	Unhealthy for Sensitive Groups	Orange
151 to 200	Unhealthy	Red
201 to 300	Very Unhealthy	Purple
301 to 500	Hazardous	Maroon

The integrated smart display also indicates the maximum partial size currently being filtered as well as the remaining lifetime of the filter.

The fine dust room sensor is designed to measure and transmit indoor concentrations of PM2,5 (Concentrations of fine particulate matter)



### Specifications ;

- \* 7" Touch panel
- \* PLC control
- \* Air quality indicator PM2,5 (Fine Dust Room Sensor)
- \* Datalog transferring with USB port
- \* PC connection with RJ45 cable
- \* Particle measurement and storing particle data monthly / yearly
- \* Automatic working mode according to air quality (PM2,5)
- \* Time schedule
- \* Password protection
- \* 6 speed fan control / Auto mode
- \* ESP filter status/alarm
- \* UVC filter life counter/alarm

## Monitoring and Datalog the Concentrations of fine particulate matter

Monitoring allows air quality specialists to collect data on interior conditions, identify source issues, and formulate solutions for mitigating problems.

Monitoring can also serve to ensure that solutions have been successful.

USB 3.0 interface  
You can transfer data to USB stick  
Logging rate: 15 seconds  
LCD confirms logger operation and displays near real-time measurement data  
On-screen alarms notify you when a sensor reading exceeds set thresholds  
When memory full, automatically delete first date & time  
Factory calibrated

## Main features of Hepavent Air Purifiers Why should we choose hepavent ?

- Reduces within few minutes the aerial contamination into a room up to 99,99%\*
- Scientific tests performed by independent laboratories show its efficacy against all viruses, bacteria, spores\*
- The high dosage germicidal system (UV-C) increases efficacy up to 400% vs all other devices on the market\*
- It can work 24 hours a day with in presence of people: no fraction of the germicidal radiation can in fact strike directly eyes and skin
- Specially designed UVGI lamps do not create ozone for a total operative safety
- On/Off cycles completely automatic, easy installation and safe maintenance
- Reduces use of surface disinfectants in the office, does not nebulize chemicals in the air, no filters to change
- Installed in several hospitals and surgical theaters in respect of the international regulations (CE marked)

The unit is mobile and thanks to its robust wheels the machine can be transported easily. Depending on the application, there are five different model options available. These include an all-round filter with high levels of efficiency to meet any application. All models have been specifically developed for the targeted elimination of viruses, bacteria, odours, allergies or volatile organic compounds.

### Airflow Direction;

The direction of airflow in an mobile air purifier is important. The UPM/EC range has inlets that bring air in through the sides at the bottom of the unit. This means that particles, including airborne micro organisms are drawn downwards towards the floor rather than projected up wards into the breathing air of the rooms occupants. Purified air is discharged from the top of the unit to the air strata in the room where it enters in the breathing air space.



### Noise;

The casing of the unit is made from acoustically insulated panels set into a box section frame. Also the fan which is the bit that generates the noise, is sandwiched between silencer stages which helps to suppress noise.

\* It is valid when the unit is operated in the air flow condition where it can filter the most efficiently.

## Comparison Chart

	H 13 HEPA	Ionizer Air Cleaning Unit	hepavent®	Air Purifier with Electrostatic Filter	Air Purifier with Activated Carbon
Dust Mites	●	●	●	●	
Pollen	●	●	●	●	
Mold	●	●	●	●	
Bacteria	●	●	●	●	
Virus > 3micron	●	●	●	●	
Virus < 3micron			●	●	
VOC			●		●
Odor	☾		●		●
Smoke	☾	●	●		●

## H14 Hepa Filter

HEPA 14, also called H14, is the filter class commonly used to filter out bacteria, viruses, and other airborne contaminants in sensitive healthcare environments.

### What does HEPA mean?

HEPA is an abbreviation of High-Efficiency Particulate Air. It is a series of highly efficient filters, classified according to standard EN 1822 for particulate filters. The filters are divided into different classes depending on how good they are at filtering out the particle size that is most difficult to capture, called MPPS (Most Penetrating Particle Size).

HEPA filters are divided into two classes: HEPA 13 and 14. HEPA 14 is the filter commonly used in environments that are particularly sensitive to airborne particles, e.g. healthcare environments and laboratories.

All HEPA 14 filters are tested individually and have at least 99.995% filtration efficiency for 0.1–0.2 µm particles\*. It is the particle size that is most difficult to capture. For larger as well as smaller particles, the filter has even higher filtration efficiency.

The influenza B virus is estimated to be about 0.12 µm and the new coronavirus at most, 0.16 µm. They may for some time be encapsulated in the droplets (about 10 µm) that spread in the air when we cough and sneeze as well as in the aerosols (about 1 µm) in our exhaled air. A single breath can contain anywhere from 1,000 up to 50,000 microdroplets.

While the droplets are in the air for a certain period of time, it is difficult to know for how long, how far they can move, and how much is needed to pose a risk of infection. The microdroplets are also affected by air temperature, humidity, and movements.

For particle filtration, we use HEPA filters (HEPA 14) according to standard EN 1822, or ePM1 (60 or 80%) according to standard ISO 16890.

**HEPA 14: Minimum separation efficiency 99.995%**

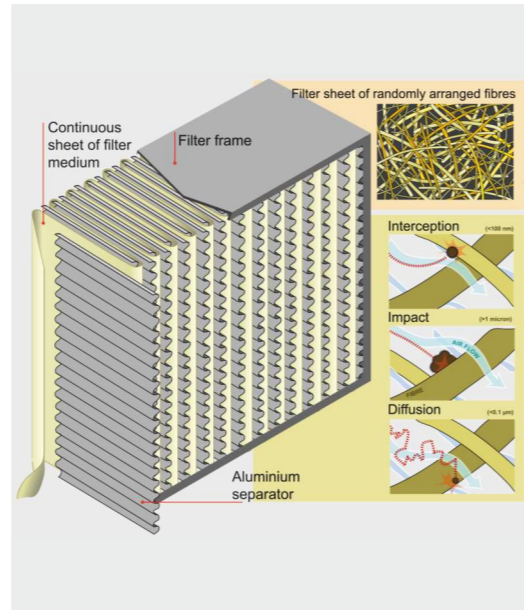

## F7 Compact Filter

Compact minipleat F7 filters are primarily used in turbomachinery air intake systems, ventilation and air conditioning systems, laboratories, chemical and pharmaceutical plants as well as dust removal hoods at workplaces.

Their innovative minipleat technology with hot melt pleat fixation ensures optimum utilization of filter surface and highest physical strength. The filter media used in these filter cassettes are high quality, wet-laid glass-fibre materials.

Compact minipleat F7 filters provide maximum filter surface area while taking up minimum space, permitting installation of efficient filtration systems even in extremely cramped spaces.

- \* Long service life, cost-efficient operation
- \* Water-repellent
- \* Reliable operation even at 100% relative humidity
- \* Reliable operation at temperatures up to 80 °C
- \* Filter media joined to frame with cast airtight joint
- \* Continuous foamed-in-place seal
- \* Corrosion-proof polystyrene housing, fully incinerable

## Electrostatic Filtering Technology

Thanks to its high collection efficiency of submicronic particles and to its strong electric field, the Electrostatic filter technology has an elevated antibacterial power and is active on pollen, fine dust, toner, mold, smog, viruses, bacteria and tobacco smoke. The contaminants, according to their size, can enter inside our body and wear out certain organs. Among the most dangerous airborne substances we find Coronavirus and Legionella, very topical problems that cause millions of deaths every year. With electrostatic filters this problem is eliminated as pollen, dust mites, fungus and other contaminants are captured and inactivated.

The efficiency of bacterial elimination is 98-99% ;

- \* Airborne bacteria, like Micrococcus luteus
- \* Yeasts like, Rhodotorula rubra
- \* Bacillus anthracis
- \* Molds and microbes present in natural air spectrum

The Hygiene Institute of Berlin has certified that electrostatic filters are able to remove from the air the airborne bacteria, yeasts and molds with an efficiency between 98% - 99%.

	BEFORE Test A	AFTER Test B
<b>M.luteus</b>	2896	0
<b>R.rubra</b>	830	9
<b>Moulds</b>	548	2



### Bacterial colonies growing on plate exposed the air



Our system with electrostatic filters is made of ionized aluminum active plates. It is composed of a treatment system which separates the airborne particles. Contaminating particles which go through the system are attached to electrodes. By this means, while going through the system the particles are charged and attached to the electrodes regardless of their size. Eventually, any kind of contaminated air is given back to the environment after it was cleaned through the system.

In our electrostatic filter there is a special power source and electric setting which increases electrostatic charges. In this system voltage (volt) and resulting current (mA) ionizes the particles. A extensive electric field is created on the filter surface to capture the particles. This feature prolongs the time for the filter to get dirty. Electrostatic filters are very effective at capturing very small (<1 micron) particles, fibers and biological materials and they do not lose their filtering capacity as contaminants accumulate in time. Power consumption is very low (about 4.7W for 1000m3 air circulation). Efficiency is maintained through entire process cycle. Because it takes longer for the filter to get dirty, it is possible to schedule periodic maintenance services. Using a mild detergent, the aluminum electrostatic filter can simply be washed by the user, and then be put into service when it is dry. Our product, which comprises high technology ESP (Italy) module is in infinite EN 16890 filter class.

### Electrostatic Filter Sample Selection Criteria

Particle size (µm)		Spectral efficiency after each phase of clogging by dust synthetic %					
		Costant Pressure drop [Pa] FE Electrostatic Filter					
		63	47	34	25	17	10
Interval	Average	Air flow m3/h					
		3360	3000	2550	2100	1700	1300
0,12±0,15	0,13	59,8±2,6	65,7±0,7	77,0±1,2	89,0±0,5	95,5±0,5	98,4±0,2
0,15±0,20	0,17	59,1±0,5	66,8±1,4	76,7±1,3	88,7±0,7	95,2±0,6	98,7±0,3
0,20±0,25	0,22	60,0±1,6	67,3±0,8	77,5±0,4	88,4±0,7	95,2±0,4	98,4±0,2
0,25±0,35	0,30	62,0±1,0	69,9±0,8	78,7±0,9	89,5±0,4	95,8±0,3	98,6±0,1
0,35±0,45	0,40	66,7±1,5	73,4±0,7	82,5±0,5	91,8±0,3	97,1±0,1	98,8±0,1
0,45±0,60	0,52	71,7±1,8	78,8±1,6	86,6±0,8	94,4±0,5	97,6±0,3	99,0±0,2
0,60±0,75	0,67	76,2±1,5	82,0±1,0	90,4±0,5	95,9±0,4	98,1±0,3	99,2±0,2
0,75±1,00	0,87	82,0±0,9	87,3±0,9	93,4±0,3	97,2±0,3	98,8±0,4	99,2±0,3
1,00±1,50	1,22	89,2±0,9	92,2±1,1	95,9±0,7	98,4±0,4	99,1±0,3	99,4±0,2
1,50±2,00	1,73	95,7±1,1	96,9±1,1	98,1±1,0	99,1±0,8	99,6±0,3	99,5±0,4
2,00±3,00	2,45	98,2±1,6	98,4±0,5	99,2±0,7	99,6±0,7	99,8±0,5	99,9±0,3
Speed air through the filter [m/s]		4	3,5	3	2,5	2	1,5
Mechanical filter class		F8	F8+F9	F9	F9+E10	E10	E11
Mechanical Initial pressure drop [Pa]		100		90		60	50
Norms		EN779:2012		EN779:2012		EN1822:2009	EN1822:2009

## Germicidal UVC Lamps

The special high dosage **UV-C lamp** in the HV kills bacteria, viruses, moulds and other primitive organisms in a safe and efficient manner.

There are a number of things that Hepavent have got right in the design that other manufacturers of UVC air purifiers have typically got wrong.

**UVC Chamber** : UVC air purifiers are all about delivering a dose of energy that can penetrate the DNA or RNA of micro organisms to damage the strands so that the spore, bacteria or virus is rendered incapable of replication.

That dose has two contributing factors. UVC intensity and time of exposure that the airborne micro organisms have to the UVC. The ranges cleverly locates its UVC lamps in the biggest void space in the unit which is where the air comes into the machine. This makes that UVC chamber and therefore the exposure time to the UVC energy as long as possible. That is brilliant when you consider that many UVC air purifiers in the market do not even have a UVC chamber!

**UVC Dose**: With the combination of lamps and the UVC chamber size, the UVC dose is very high and this is good news because it means that it will deactivate many of the problem micro organisms including MRSA, influenza, SARS , Covid -19 and TB to as near to 100% as matters, in one pass.

The air in air conditioning and ventilation systems is the ideal transport medium for microorganisms such as bacteria, mold spores, yeast, algae, protozoa and viruses. In particular, water-bearing and moist parts of ventilation and air conditioning systems such as dehumidifiers, air washers and circulation spray humidifiers, in combination with appropriate conditions, form the ideal breeding ground for microbial growth. Even the latest filter technology is unable to prevent contamination of HVAC systems in the long term. On the contrary: Filters themselves can represent foci of germs. The contaminated air is then transferred unhindered to the office and administration buildings, clinics, laboratories or the production and sales rooms of the food industry - to name just a few sensitive areas - via air conditioning and ventilation. This can lead to malaise or even illness. Employees or patients are endangered unnecessarily, laboratory results are affected. Contamination cannot be prevented.

To prevent this, we filter with Hepavent UVC lamp chamber;

- Prevention of germ contamination in HVAC systems up to 99%
- Ensuring the hygiene requirements of VDI 6022
- Ensuring working and test conditions in laboratories
- Reduce the risk of contamination in office administration buildings and meeting places
- Almost maintenance-free
- UV disinfection has many advantages over chemical disinfection. It does not produce toxins, volatile organic compounds and dangerous by-products.
- With UVC lamp, which radiates at 253.7nm wavelength in Hepavent, it inactivates by attacking the DNA of bacteria, virus, amplicons and other microbes emerging after PCR. UVC light penetrates the microorganism cell content and disrupts the structure of the DNA molecule. It does this by destroying genetic information in DNA.

## Radiation Doses for Inactivating Various Viruses

### RNA-Viruses

<b>Paramyxovirus</b>	<b>35 (15-55)</b>
Sindbis virus	55
Newcastle Disease	15
<b>Orthomyxovirus</b>	<b>35</b>
Influenza	35
<b>HIV (Lentiv)</b>	<b>1438 (600-2400)</b>
HIV (HTLVIII)	600
HIV (Sup T1)	1450
HIV (H9)	2400
HIV (PHA-stim. PBL)	1300

<b>Picornavirus</b>	<b>72 (36-186)</b>
Poliovirus	110
Poliov type 1 Mahoney	67
Poliov	133
Poliov type 1	36
Poliov Mahoney	45
ECBO	80
Coxsackiev	186

<b>Reovirus</b>	<b>102 (48-163)</b>
Reovirus type 1	48
Reov type 1 (Lang str)	163
Rotav	159
Rotav SA11	65

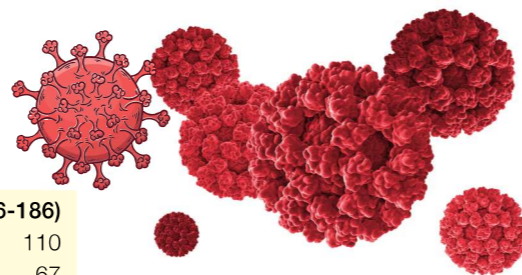

## Activated Granule Carbon

Activated charcoal has a massive surface space, which can be utilized to hold large amounts of gases. This type of filter is an absorbent filter that will retain certain vapors passing through it to filter odors or chemical gases which kept viruses hanging in the air for a long time.

### Indoor Air Quality is Critical to Patient and Worker Safety

Clean air is vital in hospital and healthcare facility operations to protect patients, staff and visitors from airborne diseases and infections, as well as to provide a comfortable, healthy and odour-free environment. The indoor air quality in the facility, referring to the air breathed by the building's occupants, is of primary importance because of patients' suppressed immune systems, making them more susceptible to adverse health effects. Poor indoor air quality ranks as one of the top five environmental risks to public health.

### The air inside your building can contain:

- Moulds, spores, pollens
- Carbon monoxide, radon, volatile organic compounds (VOCs)
- Bacteria, viruses and by-products
- Vehicle engine exhaust, exhaust from industrial plants
- Asbestos, clays, elemental particles and man-made fibres

Activated carbon has special properties that allow it to remove volatile organic compounds (VOCs), odors, and other gaseous pollutants from the air. It accomplishes this in a way that is different from other air purifiers like HEPA that only filter particle pollution from the air. Carbon air filters trap gas molecules on a bed of charcoal, a process that has a surprisingly colorful history. Here you will dive deep into how they work.

The UVC frequency is not the type of UV that creates ozone and hydroxyls. This means that the UVC will not treat odours and volatile organic compounds on the airflow. The carbon filter stage however will capture these gaseous contaminants without the use of ozone.

Media is composed of a combination of activated alumina and other binders, in spherical, porous pellets. Potassium permanganate is impregnated to this media combination in order to provide optimum adsorption, absorption, and oxidation of various gaseous contaminants. Potassium permanganate is applied uniformly during pellet formation and is distributed throughout the pellet volume. This process provides the maximum amount of impregnant for chemical reaction and optimal performance. Targets acidic gases, volatile organic compounds, reactive molecular weight organics.

### Target contaminants include;

- Formaldehyde
- Hydrocarbons (VOCs)
- Hydrogen sulfide
- Lower molecular weight aldehydes and organic acids
- Nitric oxide
- Nitrogen dioxide
- Sulfur dioxide

Our gas phase filters provides a stronger adsorption capacity for compounds (such as hydrogen sulfide, mercaptans, sulphur dioxide, chloride, hydrogen chloride, nitrogen oxides, formaldehyde and ammonia) which are not adsorbed as strongly by general active carbon filters. System's gas phase carbon filter can be used for a broad range of chemicals. The load factor capacity index shows the approximate amount of toxic substance which the filter can adsorb. When a 10 kg filter has an index of "4", it means that upto 50%, i.e. 5 kg toxin can be adsorbed. The index doesn't indicate the filters efficiency and the approximate weight of contaminant which can be adsorbed. You can find the load factor capacity index details in our website.

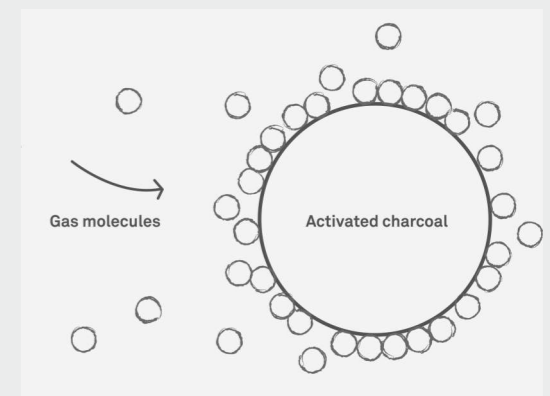



**HOSPITALS AND HEALTH FACILITIES**

• **Patient Waiting Rooms**

Infection is very high, especially in hospital waiting rooms where sick and prone patients are brought together. Because even mild infections may not be able to survive when a person's body defenses are low.

• **Emergency Services**

Environments where there is too much patient circulation with unknown disease risk are places that are both risky in terms of both particle and infectious diseases.

• **Burn Units**

Burn units with the highest risk cause extra damage to the patient by microorganism infection caused by airborne infection.

• **Air Conditioned Environments**

Air conditioners in health areas capture pathogens and microorganisms in the environment, provide a breeding environment and return to the environment. Hepavent units adsorb particulate matter and unpleasant odors. Thanks to the UVC lamps inside, it removes microorganisms from the environment. Hepavent units are designed to alleviate the biological load in the environment.



**GMP MANUFACTURING**

- **Regulatory Compliance:** Meets stringent air quality requirements (EU GMP Annex 1, ISO 14644) for contamination control.
- **Product Safety:** Reduces contamination risk during drug, biologic, or medical device production.
- **Personnel Protection:** Protects operators and technicians from bioaerosols and chemical exposure.
- **Versatility:** Can be relocated and deployed across various zones for process-specific needs.



**LABORATORIES**

• **IVF (IVF) laboratories** are among the laboratories where air quality is important. Embryos must breathe air just as we do. Air quality is very important because these small embryos do not have lungs to act as filters to contaminate air.

• In ventilation systems operating with a fresh air system in food or biotechnology laboratories, the outside air added to the laboratory air is not always clean air, so it must be filtered in the air coming from the outside. This filtration should be in terms of both particle, odor (chemical or biological) and microorganism.

• The chemicals used in the laboratory are adsorbed in the fastest way and removal from the environment is important for human health.

• Since organic volatile molecules are among the most important factors causing cross contamination, removal of odor molecules from the environment is important for laboratory functioning.

• Microorganisms that are lower than the weight of air flying in the air are sensitive due to the importance of the studies carried out with the UVC lamp because it affects the work done.



**CLEANROOMS**

In cleanroom environments where strict airborne particulate and microbial control is required (ISO 5–8 / GMP Grade A–D), portable medical-grade air purifiers serve as a flexible solution for:

- Supplementing fixed HVAC/filtration systems
- Rapidly improving air quality during contamination events
- Providing clean zones during maintenance or upgrades
- Temporary extension of cleanroom boundaries or entry areas



**Veterinary Clinics**

Reduce airborne transmission of viruses and bacteria between animals and staff.  
 Maintain clean air in treatment and surgical rooms.  
 Control odors, allergens, and dander in waiting and recovery areas.  
 Support infection prevention protocols in high-risk zones.  
 Allergen Reduction: Captures fur, dander, and particulate matter, reducing allergic reactions for staff and visitors  
 Staff & Animal Protection: Enhances biosafety by reducing exposure to airborne pathogens like Bordetella, Parvovirus, and Mycoplasma..



**Hair Transplant Clinics**

Infection Control: Reduces airborne bacteria, viruses, and dust during open-skin procedures  
 Patient Safety: Minimizes the risk of postoperative infections or follicle rejection.  
 Procedure Quality: Maintains air purity standards, improving graft take rates and overall success.  
 Staff Protection: Shields surgeons and assistants from exposure to bioaerosols and skin particles.  
 Compliance: Supports hygiene protocols aligned with ISO, CDC, and WHO guidelines.



**Mobile Clinics**

Mobile clinics operate in compact, often enclosed environments where air circulation and hygiene are limited. Medical-grade portable air purifiers play a vital role by:

- Providing localized air disinfection in tight, shared spaces.
- Removing airborne viruses, bacteria, and pollutants in real time.
- Supporting infection control protocols during mobile diagnostics and treatments.
- Enabling clean air delivery in remote or underserved locations.



**Dental Offices**

The dental workplace can expose dentists, staff, and patients to a wide variety of air pollutants during routine dental work, including infectious aerosol particles from high-speed instruments as well as airborne pathogens like bacteria and viruses. The Hepavent series was specifically developed to provide flexible, effective, and affordable air cleaning solutions for dental offices for infection control. The use of high-speed drills and ultrasonic scaling equipment generates fine droplets and aerosol particles that are light enough to stay airborne for hours. Bacteria and viruses, which are contained in drill aerosols consisting of million of micro-droplets, are easily inhaled and constitute a potential source of infection.



**The Food Processing Industry**

One of the greatest public safety concerns for the food industry and regulators is the risk of food contamination during manufacturing, with the potential for large-scale outbreaks of illness or infection. Airborne microbiological bacteria pose significant risks during food production. Containment and removal of these airborne bacteria can substantially reduce the potential for food contamination.



Shielding  
 Healthcare  
 Heroes  
 from  
 Airborne  
 Threats.